

1. 概述 INTRODUCTION

微波低通滤波器 LF 系列产品设计用于 WLAN、DSTV 和无绳电话机中，具有低的插入损耗、高的衰减和小体积 SMD 片式设计，能减少复杂的调校工作，可以简化电路设计。

Microwave Low-Pass filter LF series are designed to be used in WLAN、DSTV & cordless phones with low insertion loss and high attenuation as well as small size SMD chip design, which can simplify your complex tuning and circuit design.

2. 型号 Part Number

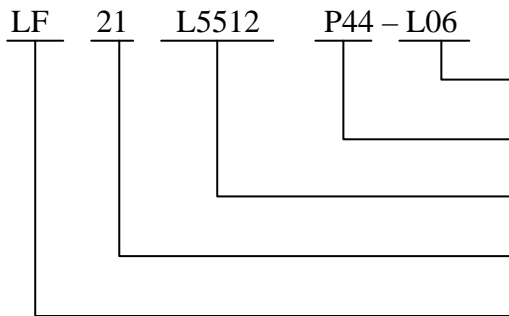

标准规格，编号 L06/ Normal Type: L06
 平面设计结构/Planar Design Series: P44
 低通滤波器/Low Pass Filter: 5512 MHz
 产品尺寸/Size: 2.0×1.25×0.95
 多层结构滤波器/Multi-layer Filter

3. 外型尺寸 Dimensions (Unit: mm)

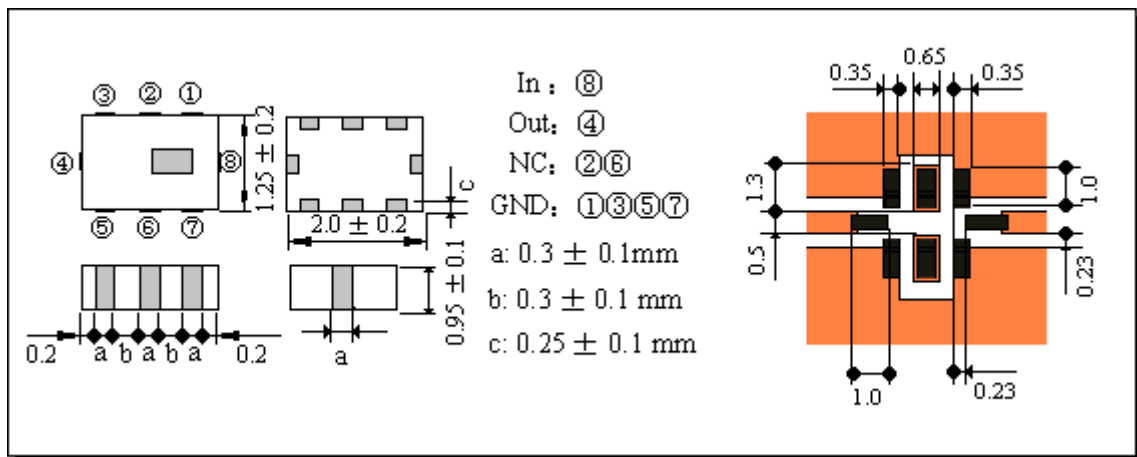

4. 结构及材料 Structure and Material

| No | Part Name 名称 | Structure and Material 结构及材料 |
|-----|---------------------------|-------------------------------|
| 4.1 | Resonator 谐振体 | Dielectric Material LTCC 介质材料 |
| 4.2 | In/Output Terminals 输入/输出 | Ag 银 |
| 4.3 | Ground Base 接地面 | Ag 银 |

5. 电气性能 **Electrical Characteristics**

| No. | Item (项目) | Specifications (特性) |
|-----|------------------------------------|--------------------------|
| 5.1 | Center Frequency 中心频率 fo | 5512 MHz |
| 5.2 | Insertion Loss 插入衰耗 | ≤1.3 dB (at 25°C ±5°C) |
| | | ≤1.6 dB (at -40°C ~85°C) |
| 5.3 | Band Width 通带宽度 | 5150~5875 MHz |
| 5.4 | Ripple (in BW) 通带波动 | ≤0.5 dB |
| 5.5 | V.S.W.R (in BW) 驻波比 | ≤2.0 |
| 5.6 | Attenuation 阻带衰耗 | ≥25dB (10300~11750 MHz) |
| 5.7 | Permissible Input Power 输入功率 (MAX) | 1 W |
| 5.8 | In/Output Impedance 输入/输出阻抗 | 50 Ω |

6. 特性曲线 **Characteristic curve**



7 环境试验后允许误差 Post Environmental Tolerance

经环境试验后允许比起始读数偏差见下表

| No. | Item (项目) | Post Environmental Tolerance (环境试验后允许附加误差) |
|-----|-----------------------------|---|
| 7.1 | Center Frequency 中心频率 f_0 | ± 2.0 MHz |
| 7.2 | Insertion Loss 插入损耗 | ± 0.5 dB |
| 7.3 | Band Width 通带宽度 | ± 5.0 MHz |
| 7.4 | Ripple (in BW) 通带波动 | ± 0.5 dB |
| 7.5 | V.S.W.R (in BW) 驻波比 | ± 0.2 |
| 7.6 | Attenuation 阻带衰减 | ± 2.0 dB |

Post Environmental Tolerance (Refer to the table)

8 环境试验 Environmental Test

| | | |
|-----------|-----------------------------|--|
| 基准条件：温度范围 | Temperature range | $25 \pm 5^\circ\text{C}$ |
| 相对湿度范围 | Relative Humidity range | 55~75%RH |
| 工作温度 | Operating Temperature range | $-40^\circ\text{C} \sim +85^\circ\text{C}$ |
| 贮藏温度 | Storage Temperature range | $-40^\circ\text{C} \sim +85^\circ\text{C}$ |

8.1 耐振动 Vibration Resist

在振动频率为 10~55Hz 振幅为 1.5mm 沿 X.Y.Z 方向各振动 2 小时后测试符合表 7.1~7.6 规定。

The device should satisfy the electrical characteristics specified in paragraph 7.1~7.6 after applied to the vibration of 10 to 55Hz with amplitude of 1.5mm for 2 hours each in X, Y and Z directions.

8.2 耐跌落冲击 Drop Shock

在 100cm 高度处按 X, Y, Z 三个面分别自由跌落在木制地板上共 3 次后测试符合表 7.1~7.6 规定。

The device should satisfy the electrical characteristics specified in paragraph 7.1~7.6 after dropping onto the hard wooden board from the height of 100cm for 3 times each facet of the 3 dimensions of the device.

8.3 耐焊接热 Solder Heat Proof

能承受经 120~150°C 的温度预热 120 秒后, 在 255°C+10°C 的焊锡浸 5±0.5 秒, 或 300°C-10°C 的电烙铁焊接 3±0.5 秒, 焊接面无损伤。

The device should be satisfied after preheating at 120°C~150°C for 120 seconds and dipping in soldering Sn at 255°C+10°C for 5±0.5 seconds, or electric iron 300°C-10°C for 3±0.5 seconds, without damage.

8.4 结合力试验 Tensile Strength of Terminal

在产品电极端子上或表面上应能承受 1kg 垂直拉力 10±1 秒。

The device should not be broken after tensile force of 1.0kg is slowly applied to pull a lead pin of the fixed device in the lead axis direction for 10±1 seconds.

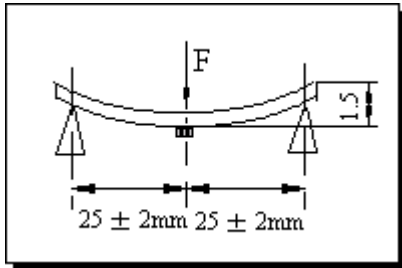
8.5 耐弯曲试验 Bending Resist Test

将产品按图焊在 $1.6 \pm 0.2\text{mm}$ 的 PCB 板中间, 由箭头方向施力: 1mm/S , 弯曲距离: 1.5mm , 保持 $5 \pm 1\text{S}$, 产品金属层无脱落。

Weld the product to the center part of the PCB with the thickness $1.6 \pm 0.2\text{mm}$ as the illustration shows, and keep exerting force arrow-ward on it at speed of 1mm/S , and hold for $5 \pm 1\text{S}$ at the position of 1.5mm bending distance, so far, any peeling off of the

product metal coating should not be detected.

8.6 耐湿热特性 Moisture Proof

在温度为 $60 \pm 2^\circ\text{C}$ 相对湿度 $90\sim 95\%$ 的恒温湿箱中放置 96 小时, 在常温中恢复 1~2 小时后测试, 符合表 7.1~7.6 规定。

The device should satisfy the electrical characteristics specified in paragraph 7.1~7.6 after exposed to the temperature $60 \pm 2^\circ\text{C}$ and the relative humidity $90\sim 95\%$ RH for 96 hours and 1~2 hours recovery time under normal condition.

8.7 高温特性 High Temperature Endurance

在温度为 $85 \pm 5^\circ\text{C}$ 的恒温箱中放置 96 ± 2 小时, 在常温中恢复 1~2 小时后测试。符合表 7.1~7.6 规定。

The device should satisfy the electrical characteristics specified in paragraph 7.1~7.6 after exposed to temperature $85 \pm 5^\circ\text{C}$ for 96 ± 2 hours and 1~2 hours recovery time under normal temperature.

8.8 低温特性 Low Temperature Endurance

在温度为 $-40^\circ\text{C} \pm 5^\circ\text{C}$ 低温箱中放置 96 ± 2 小时后恢复 1~2 小时测试符合表 7.1~7.6 规定。

The device should also satisfy the electrical characteristics specified in paragraph 7.1~7.6 after exposed to the temperature $-40^\circ\text{C} \pm 5^\circ\text{C}$ for 96 ± 2 hours and to 2 hours recovery time under normal temperature.

8.9 温度循环 Temperature Cycle Test

在 -40°C 温度中保持 30 分钟, 再在 $+85^\circ\text{C}$ 温度中保持 30 分钟, 共循环 5 次后在常温中恢复 1~2 小时后测试符合表 7.1~7.6 规定。

The device should also satisfy the electrical characteristics specified in paragraph 7.1~7.6 after exposed to the low temperature -40°C and high temperature $+85^\circ\text{C}$ for 30 ± 2 min each by 5 cycles and 1 to 2 hours recovery time under normal temperature.

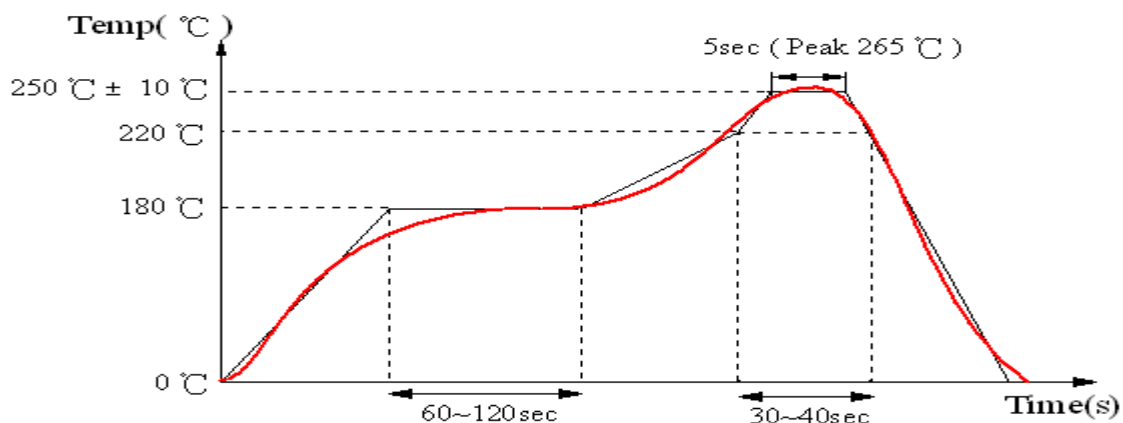
9 回流焊温度 Reflow Soldering Standard Condition

10 包装尺寸 (2012) Packaging and Dimensions

10.1 Plastic Tape

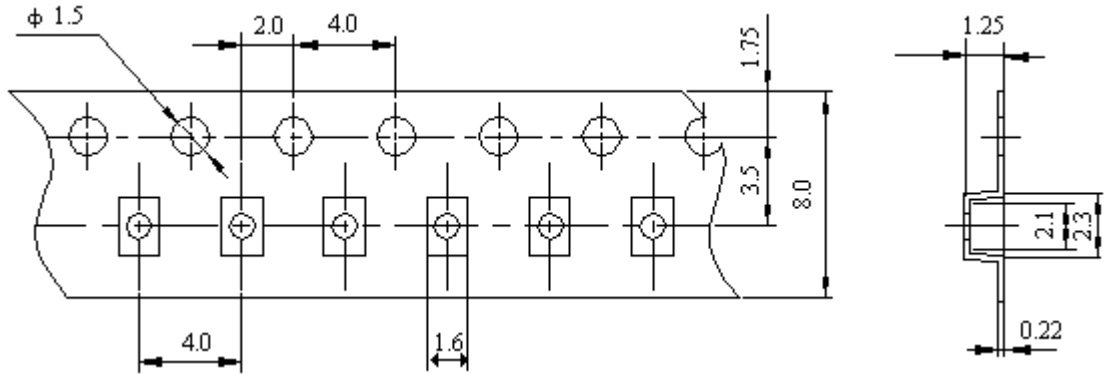

包装说明： Remarks for Package

载带尾部空穴长度 200mm，载带头部空穴长度 200mm，头部的盖带加长 250mm。

Reserve a length of 200mm for the trailer of the carrier and 200 mm for the leader of the carrier and further 200mm of cover tape at the leading part of the carrier.

10.2 Reel (4000 pcs/Reel)

